

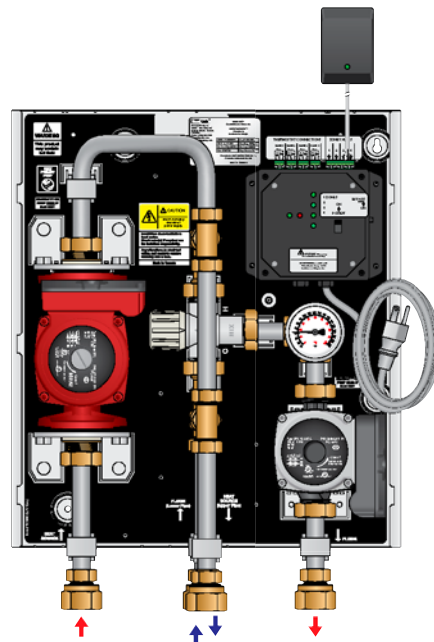

# TWH070Z, TWH070XPZ

Tankless Water Heater Panels with Zoning  
Installation, Operation, and Maintenance Manual

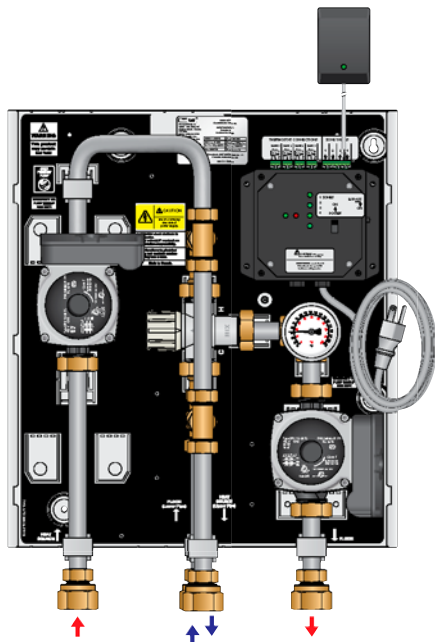
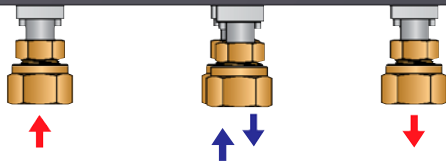
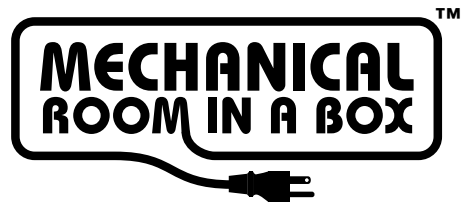
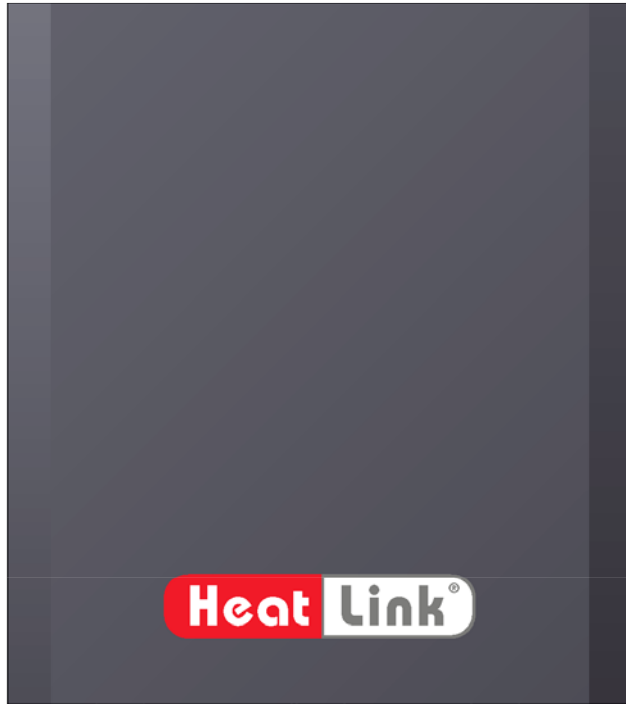

**Table Of Contents**

Warnings..... 3  
Tools Needed ..... 3  
Function..... 4  
Unpacking..... 4  
Panel Components ..... 5  
Specifications..... 6  
Panel Component Specifications ..... 6-8  
Valve Adjustments ..... 8  
Mounting..... 9  
Piping Hookup ..... 10  
Fill and Purge ..... 11  
Panel Wiring ..... 12  
Panel Control Sequence..... 13  
Troubleshooting ..... 14-15  
Maintenance ..... 15  
Application Drawings ..... 16-17

## Warnings

The zone control panel is for indoor use only and must be installed by a qualified installer/service technician. This product must be installed and operated in strict accordance with the terms set out in this manual and in accordance with the relevant requirements of the Local Authority Having Jurisdiction. Failure to comply will result in a void of warranty, and may also result in property damage, serious injury, or death.

## Servicing

Prior to commencing installation of this panel it is necessary to read and understand all sections of this manual. The symbols below are used throughout this document to ensure proper operation of the panel, and your safety. Please pay attention to these symbols.



Warning  
**Possible Hazard**



Warning  
**Live Power**



Warning  
**Hot Pipes**



Warning  
**Treated Water**



In order to avoid injury or death, switch off the power to the panel prior to inspecting or making connections to the terminal strip.

## Disclaimer

HeatLink Group Inc. shall not be responsible for errors in its brochures or printed materials. HeatLink Group Inc. reserves the right to alter its products at any time without notice, provided that alterations to products already on order shall not require material changes in specifications previously agreed upon HeatLink Group Inc. and the Purchaser. All trademarks in this material are property of the respective companies. HeatLink and the HeatLink logotype are trademarks of HeatLink Group Inc. All rights reserved.

## Tools For Installation

- Level
- Screwdriver or power drill
- Flat head bit
- Phillips head bit # 2
- 2 adjustable wrenches (or 2× 30mm wrenches and 2× 40mm wrenches)

## Function

This panel can provide mixing, distribution, and zoning for a wide variety of hydronic heating applications.

The effectiveness of the system is dependant on the system being designed and installed correctly. Proper consideration of factors such as BTU loads, outdoor design temperature, indoor design temperature, room set-point temperature(s), differential fluid temperatures, head loss, flow rates, and transfer capacities of the heat emitters is critical.

Once these factors have been considered and the system requirements determined, these can then be evaluated and compared to the zone control panel capabilities (refer to pages 5-8).

**Note:** This panel does not regulate or monitor the operating safety limit temperatures of the fluid leaving the heat source.

## Unpacking

**Step 1** Examine carton for any damage that may have occurred during shipping. If damage is visible notify your courier and supplier immediately.

**Step 2** Open the carton by removing the staples.

**Step 3** Remove the cardboard spacers from the carton, then remove the panel from the carton. Lift the panel by the base, not the enclosure.

**Step 4** There are 2 screws holding the enclosure in place during shipping. They are located at the top left & right of the panel base. Remove these 2 screws.

**Step 5** Remove the enclosure from the panel by sliding it upwards until it stops, then gently pulling outwards off.



**Step 6** Verify the following items:

- (4) Mounting screws
- (4) ¾" MBSP x 1" FPT adapters
- (6) ¾" rubber washers (2 spares)
- (2) 1" rubber washers (spares)
- (1) 24 Vac Plug-in transformer

## Panel Components

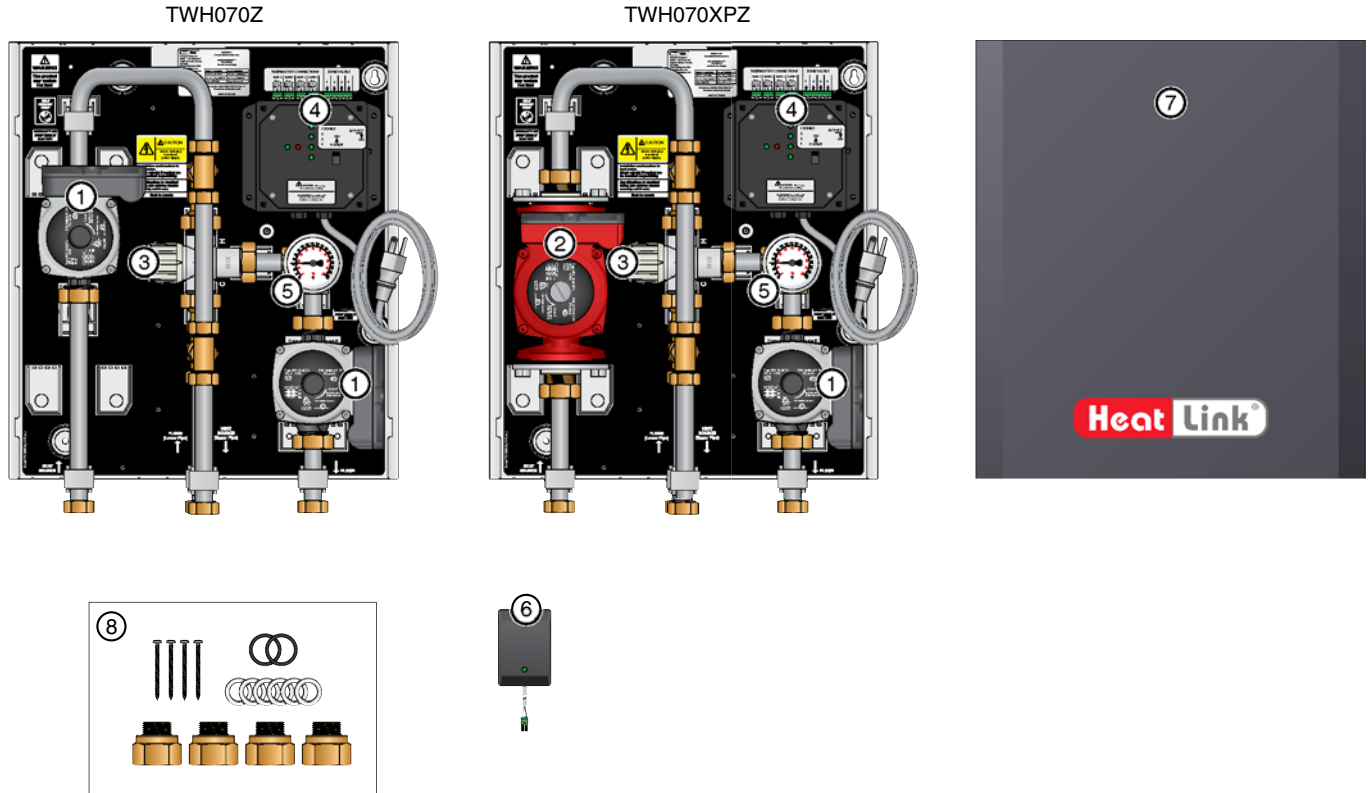

| # | Component                       | Part Number   |               |
|---|---------------------------------|---------------|---------------|
|   |                                 | TWH070Z       | TWH070XPZ     |
| ① | Circulator Grundfos UPS15-58 RU | PUMP1558      | PUMP1558      |
| ② | Circulator Grundfos UPS26-99BFC | n/a           | PUMP2699BR    |
| ③ | Thermostatic Mixing Valve       | BRAVLV13WMXTH | BRAVLV13WMXTH |
| ④ | Power Box with 6' Power Cord    | PWRB5R1       | PWRB5R1       |
| ⑤ | Thermometer                     | 76940         | 76940         |
| ⑥ | 24Vac 40VA Plug-in Transformer  | PLINTR40VA    | PLINTR40VA    |
| ⑦ | Enclosure                       | n/a           | n/a           |
| ⑧ | Accessory Pack                  | ACCTWH        | ACCTWH        |
|   | 3/4" Washer                     | WHTWSH34      | WHTWSH34      |
|   | 1" Washer                       | NTRWSH1       | NTRWSH1       |

## Specifications

|                                                  | TWH070Z                             | TWH070XPZ                            |
|--------------------------------------------------|-------------------------------------|--------------------------------------|
| Listing                                          | cETLus                              |                                      |
| Conforms to                                      | CAN/CSA-C22 No.14, UL508            |                                      |
| Dimensions                                       | 18.25"H x 16.25"W x 8"D             |                                      |
| Nominal panel output                             | 70,000 btu/hr                       | 70,000 btu/hr                        |
| Primary nominal flow                             | 4.0 US gpm @ 35°F ΔT                | 4.0 US gpm @ 35°F ΔT                 |
| Primary nominal pressure drop outside of panel   | 14 ft                               | 24 ft                                |
| Secondary nominal flow                           | 7 US gpm @ 20°F ΔT                  | 7 US gpm @ 20°F ΔT                   |
| Secondary nominal pressure drop outside of panel | 4 ft                                | 4 ft                                 |
| Max ambient temperature                          | 120°F                               |                                      |
| Max water temperature                            | 200°F                               |                                      |
| Min required flow for correct temp control       | 1 US gpm                            |                                      |
| Power supply: pre-wired on system controller     | 110 V(ac); max. current 2A          |                                      |
| Primary circulator                               | Non-ferrous, Grundfos<br>UPS15-58RU | Non-ferrous, Grundfos<br>UPS26-99BFC |
| Secondary circulator                             | Non-ferrous, Grundfos<br>UPS15-58RU | Non-ferrous, Grundfos<br>UPS15-58RU  |
| Auxiliary terminal                               | Yes                                 |                                      |
| Temperature control method                       | 1" 3-Way thermostatic               |                                      |
| Temperature control range                        | 100°F - 145°F                       |                                      |
| Valve Cv                                         | 3.9                                 |                                      |
| Piping                                           | 3/4" 304 Stainless steel tubing     |                                      |
| Piping connections                               | 1" FIP                              |                                      |
| Backplate                                        | Galvanized steel                    |                                      |
| Enclosure                                        | Powder coated steel                 |                                      |

## Panel Component Specifications

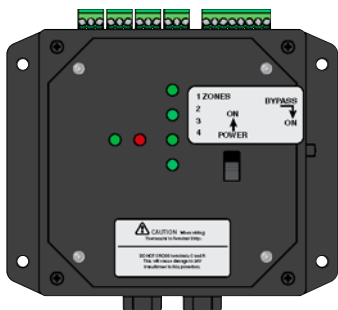

### Power Box

This module provides the required power for all electronic components on the panel, via the ON/OFF switch. Part may not be exactly as shown.

#### Specifications:

- Requires 115V power source.
- Requires a maximum 15A circuit breaker.



### 24Vac 40VA Plug-in Transformer

This plugs into and provides 24Vac power to the power box.

#### Specifications:

- Requires 115V power source.

**Circulators**

The circulators moves the heated fluid through the hydronic system when there is a call for heat from the thermostat. Primary pump on the TWH070XPZ is a UPS26-99BFC.

Specifications:

- The following pump curves apply.

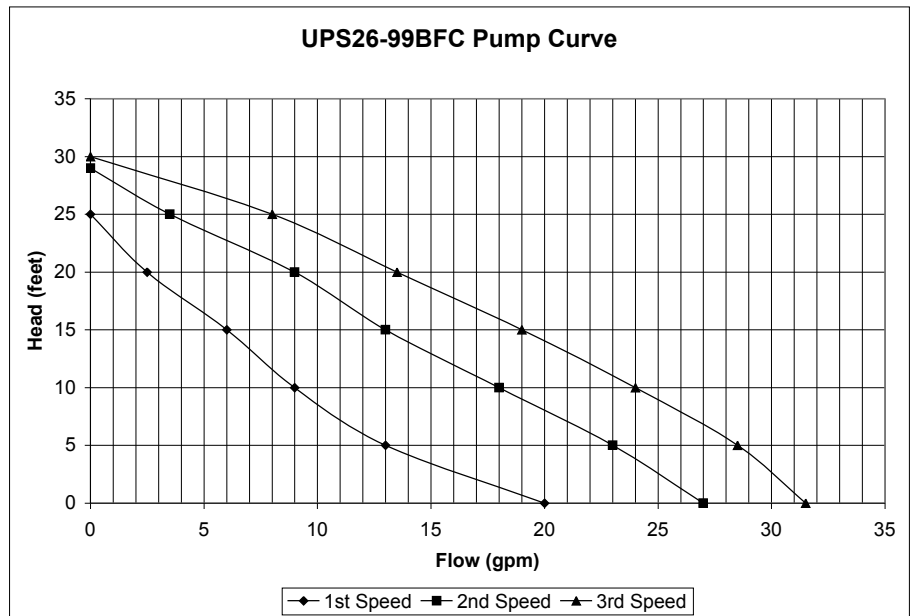
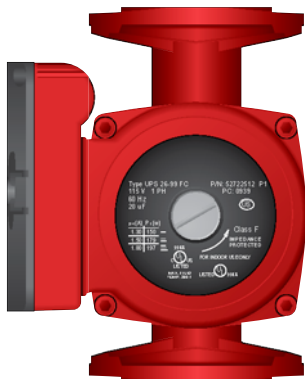
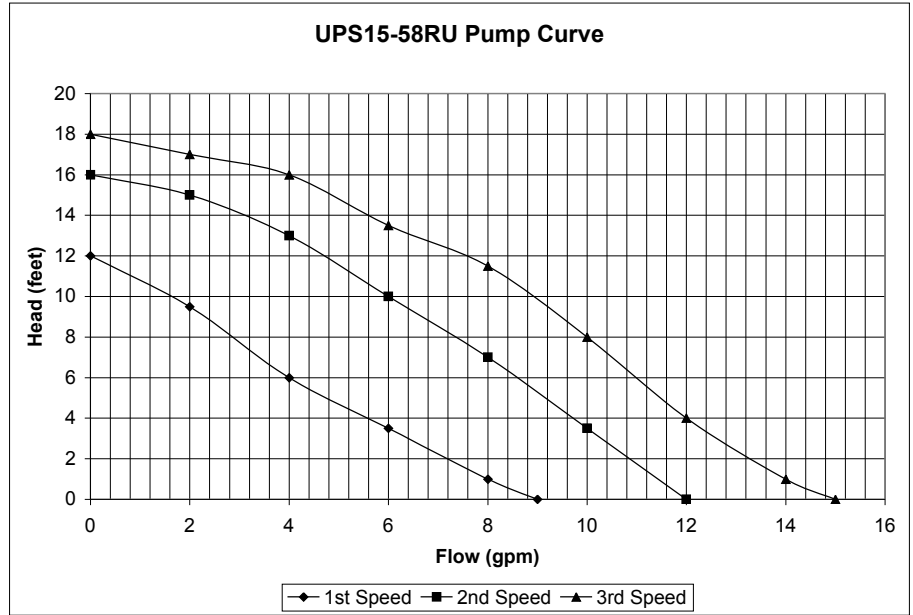

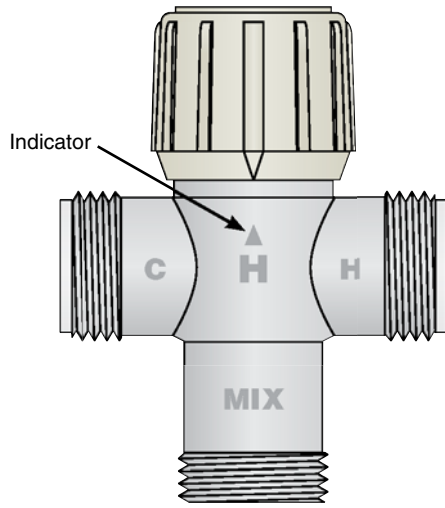

**3-Way Thermostatic Mixing Valve (TMV)**

The TMV controls the temperature of the hydronic system via a self regulating thermostat.

**Setting the TMV**

The indicator for the valve is located at the base of the knob. The mixed (desired) temperature is a function of the supply temperature and the TMV setting.

See the below chart to determine the proper setting for you system. After allowing the system to run for a short period, verify the setting and adjust if necessary.

| Supply Fluid Temp |      | Mixed Fluid Temperature |      |       |      |       |      |       |      |       |      |
|-------------------|------|-------------------------|------|-------|------|-------|------|-------|------|-------|------|
|                   |      | 0                       |      | 1     |      | 2     |      | 3     |      | 4     |      |
| 120°F             | 49°C | 96°F                    | 36°C | 104°F | 40°C | 116°F | 47°C | 117°F | 47°C | 117°F | 47°C |
| 140°F             | 60°C | 98°F                    | 37°C | 106°F | 41°C | 118°F | 48°C | 130°F | 54°C | 137°F | 58°C |
| 160°F             | 71°C | 100°F                   | 38°C | 108°F | 42°C | 120°F | 49°C | 132°F | 56°C | 145°F | 63°C |
| 180°F             | 82°C | 102°F                   | 39°C | 110°F | 43°C | 122°F | 50°C | 134°F | 57°C | 147°F | 64°C |

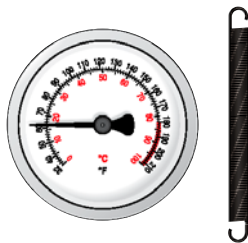

**Thermometer (76940)**

The pipe mounted thermometer reads the supply fluid temperature.

Specifications:

- Temperature range of 32-210°F (0-100°C).

## Mounting

Prior to mounting the panel, ensure the wall is capable of supporting the weight of the panel. Ensure that a 115V receptacle is within reach of the 6-foot cord and plug and 24V plug-in transformer.

**Step 1** Determine the locations and distance between the wall studs. With a level at a minimum height of 4' from the floor draw a straight line on the wall and mark the stud locations. If the panel cannot be secured directly to the studs, or suitable backing boards, plywood may need to be installed behind the panel to properly secure it in place.

**Step 2** Screw two of the supplied mounting screws into the wall studs (or backing plywood) 2" from the top of desired height, and 10-1/2" apart, leaving 1/4" of screw out from the wall.

**Step 3** Lift and place the panel onto the mounting screws.

**Step 4** Screw the two remaining mounting screws into the holes at the bottom of the panel and tighten the top two screws.

**Step 5** Before replacing the enclosure, refer to pages 10-12 for fill and purge, and proper wiring instructions.

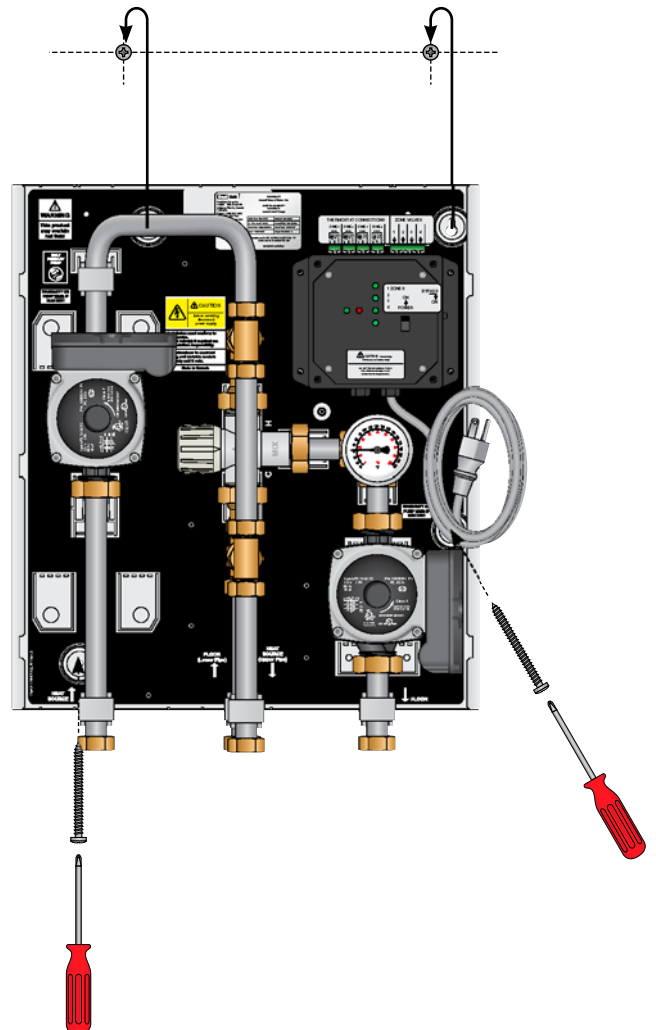
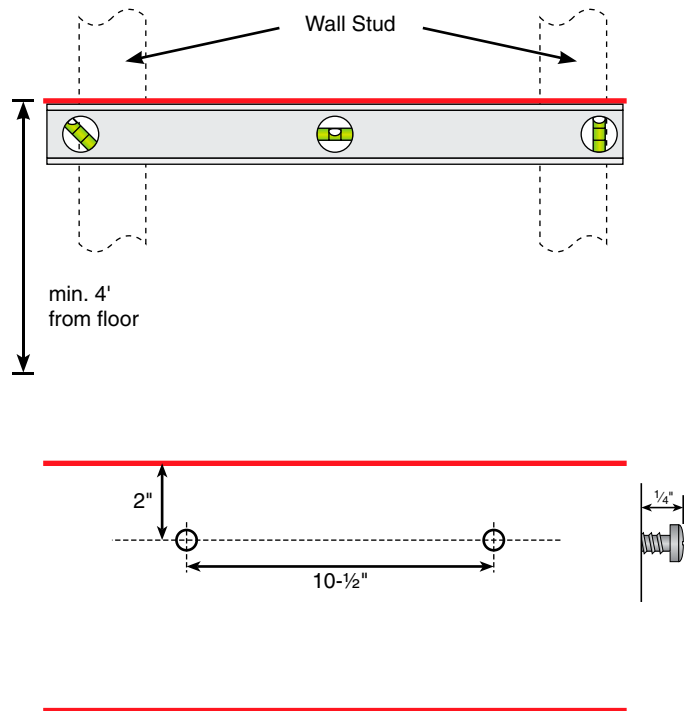

### Piping Hookup

**Step 1** Before making any connections, identify the required connections to and from the panel. Adapters are  $\frac{3}{4}$ " M BSPP x 1" FPT, and must use the supplied adapters and rubber washers.

- Step 2** Connect all adapters.
1. Connect MPT adapter (E) to copper pipe or tubing (F).
  2. Screw supplied M x FPT adapter (D) onto (E) using appropriate thread sealant.
  3. Take assembly (D)(E)(F) and place rubber washer (C) on flat surface of (D).
  4. Without disturbing rubber washer (C), place assembly against flanged stainless steel pipe (B).
  5. Slide nut (A) over adapter (D) and first finger tighten nut. Then, using two 30mm wrenches, tighten the nut **taking care not to overtighten the nut**, as this will damage the rubber washer.

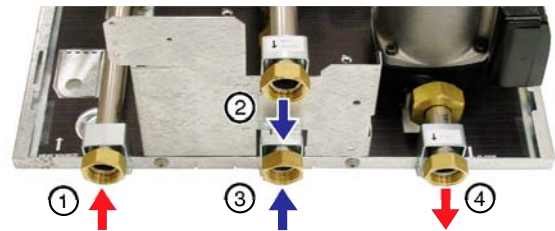

- ① Primary Supply
- ② Primary Return
- ③ Secondary Return
- ④ Secondary Supply

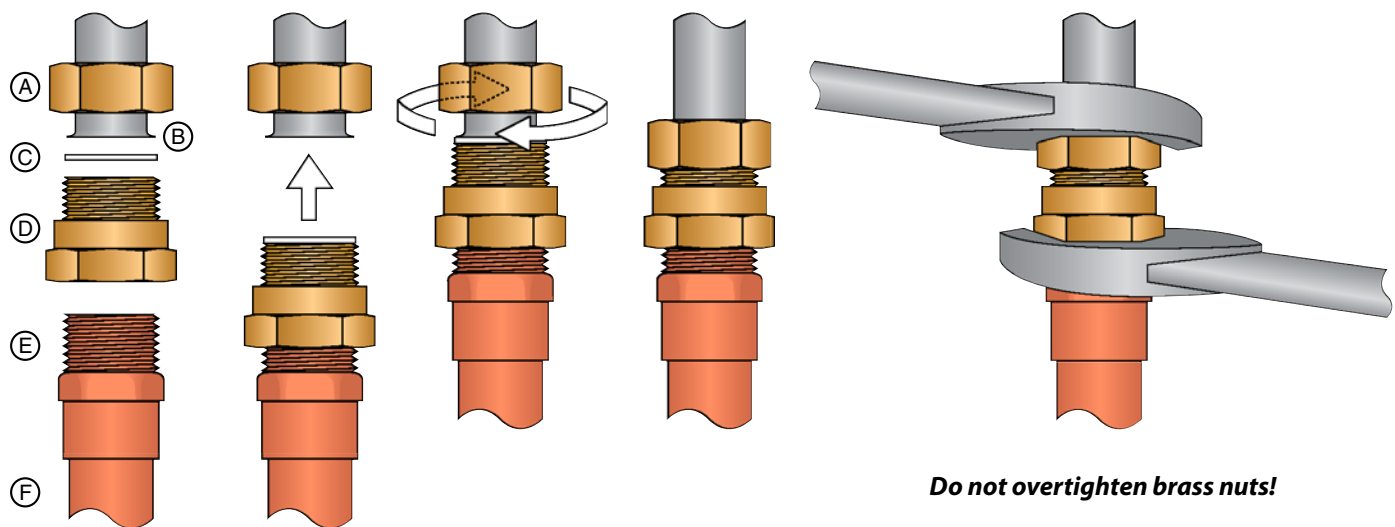

Note: Use precautions when soldering or applying heat within 16" of the panel.

## Fill And Purge

The following steps are recommended in order to fill the panel with water and purge entrained air once piping is completed, and before activation of the panel.



*The discharged system fluid from the fill and purge process is not for consumption or washing.*

**Note:** *Additional purging steps may be required for the rest of the hydronic system.*

**Note:** *Isolation and drain valves are not included with the panel, but are necessary to properly fill and purge the panel, and to isolate the panel for service.*

**Step 1** Ensure the panel is **not** plugged in.

**Step 2** Adjust the thermostatic mixing valve to a position of four (see page 8).

**Step 3** Fully close valves (A), (B), (C), (D), and (F). Fully open valve (E).

**Step 4** Attach a purge hose (not included) to (E) and a fill hose (not included) to (F). Open valve (F).

**Step 5** When exiting water from (E) is free of bubbles, close valve (E), then valve (F).

**Step 6** Remove hoses from drain valves and full open valves (A), (B), (C), and (D).

**Step 7** Check for leaks at connections. If any leaks are found, use a back-up wrench and carefully tighten until leak stops. **Do not overtighten.**

**Step 8** Readjust the setting of the thermostatic mixing valve to provide a proper mixed fluid temperature to the hydronic system (see page 8).

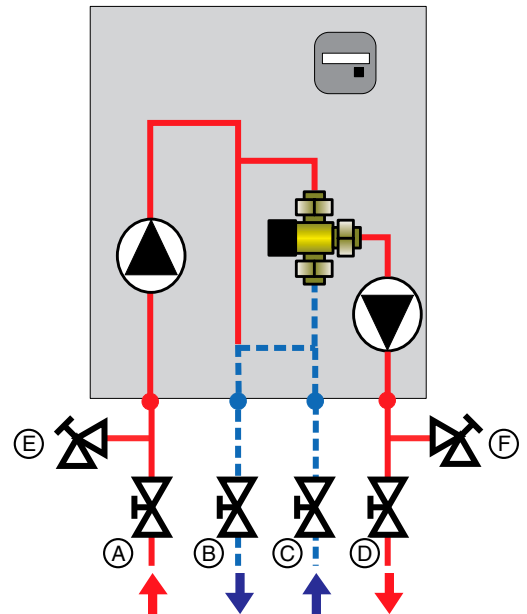

**Panel Wiring**

Note: Terminal headers are removable to make wiring connections easier.

**Thermostat Wiring**



- 24V low voltage power may be supplied to the thermostat. Wiring of thermostat should be done by qualified electrician and should meet local codes and jurisdictions. Wiring to the terminal strip requires 18 gauge 4 wire.



- Do not exceed 2VA per thermostat.
- Do not cross terminals C and R – this will damage the Power Box.

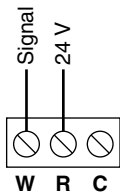

2-Wire Thermostat  
(battery only or non-electric)

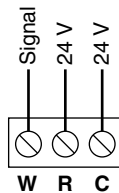

3-Wire Thermostat  
(HeatLink thermostats)

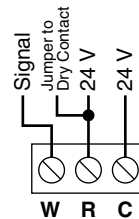

4-Wire Thermostat  
(with dry contact signal)

**24Vac Plug-in Transformer**

Plug the terminal header of the 24Vac plug-in transformer into the marked plug on the power box.

**Other Terminals**

**Auxiliary Contacts**

The auxiliary contact set is dry, meaning no supply of power is present at the terminal. The maximum allowable load is 1.5A. The auxiliary dry contact located on the terminal is to switch another device (ie. the heat source) when there is a call for heat from any zone.

**Actuator Contacts**

There are 4 sets of actuator contacts, each corresponding to a zone thermostat. The maximum allowable load is 0.4 Amps (10 VA). Maximum 3 actuators/zone. Maximum 8 actuators total.

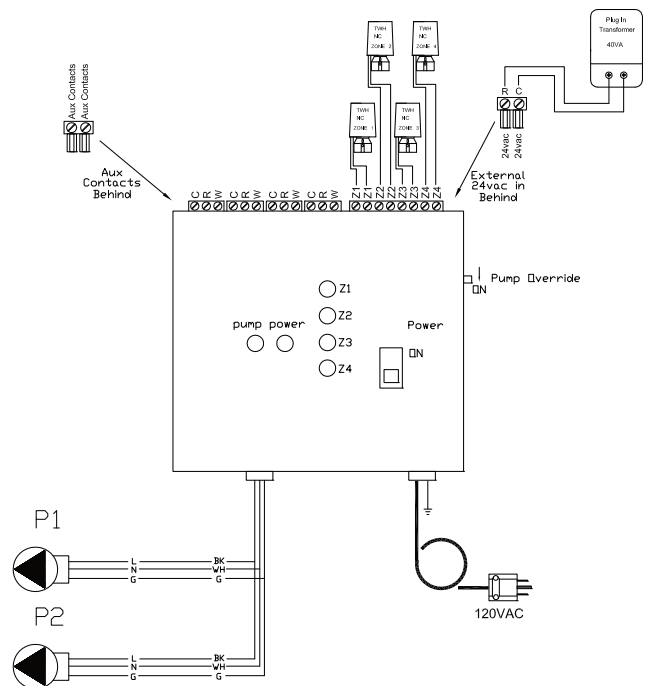

**Panel Control Sequence**

1. When the power cord ① from the power module is plugged in, and the 3-way switch is placed in the “ON” position the red LED will be lit, indicating that the panel is powered with 110V.
2. The Bypass function for the 3-way switch is for troubleshooting purposes only. Only switch to the Bypass position if the red and green LED’s on the power module do not light up during a call for heat. Please refer to the troubleshooting section of the manual for further details.
3. When a thermostat calls for heat, its internal 24V contacts close, the auxiliary terminals close, the pumps turn on, and its corresponding zone actuator opens.
4. As the circulators ② move fluid through the panel the thermostatic mixing valve adjusts the fluid temperature based on the user settings (page 6).
5. When the requirements of the thermostat are met, the internal contacts of the thermostat open, the auxiliary contacts open, the circulators stop and the zone actuator closes.
6. The circulators are activated, and all zone actuators open, once every 24 hours, for 15 minutes, to ensure that potable water in the piping is not stagnant.

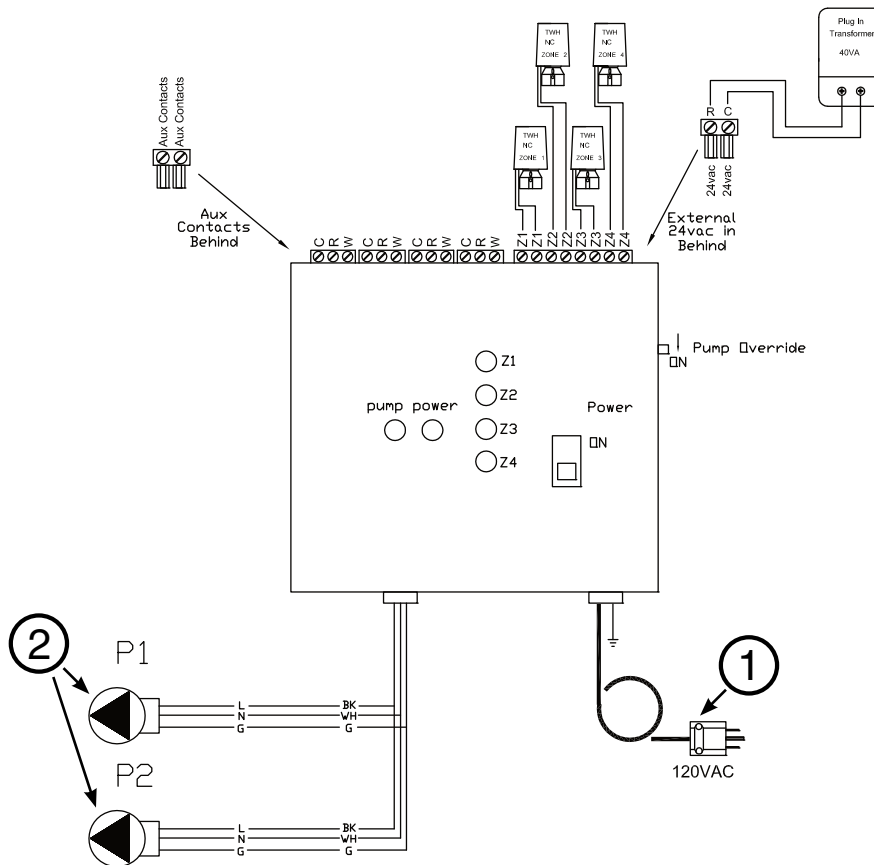

## Troubleshooting

| Problem                                                                                                                                       | Check / Verify                                                                                                                                                                                                                                                                                      | Possible Cause                                                                                                                                                                                                                                                                                                                                                                                                                                                       |
|-----------------------------------------------------------------------------------------------------------------------------------------------|-----------------------------------------------------------------------------------------------------------------------------------------------------------------------------------------------------------------------------------------------------------------------------------------------------|----------------------------------------------------------------------------------------------------------------------------------------------------------------------------------------------------------------------------------------------------------------------------------------------------------------------------------------------------------------------------------------------------------------------------------------------------------------------|
| <b>Low Temperature Within Room</b>                                                                                                            | Misplacement of thermostat location within room.                                                                                                                                                                                                                                                    | Make sure thermostat is not being influenced by an additional heat source, such as lighting or air duct.                                                                                                                                                                                                                                                                                                                                                             |
|                                                                                                                                               | Low temperature setting of the thermostat.                                                                                                                                                                                                                                                          | Adjust the temperature setting on thermostat.                                                                                                                                                                                                                                                                                                                                                                                                                        |
|                                                                                                                                               | The system fails to turn on if the thermostat is set to high setting                                                                                                                                                                                                                                | Thermostat may be out of calibration or defective. Replace thermostat.                                                                                                                                                                                                                                                                                                                                                                                               |
|                                                                                                                                               | The electronic actuator fails to open during a call for heat                                                                                                                                                                                                                                        | The electronic actuator may be improperly seated or may be defective. Replace if necessary.                                                                                                                                                                                                                                                                                                                                                                          |
|                                                                                                                                               | Low supply mixed fluid temperature.                                                                                                                                                                                                                                                                 | Adjust the thermostatic mixing valve to the appropriate setting.                                                                                                                                                                                                                                                                                                                                                                                                     |
|                                                                                                                                               | Wiring from heat source to panel.                                                                                                                                                                                                                                                                   | Check that the wiring is done properly. Consult qualified electrician prior to alteration of wiring between heat source and panel.                                                                                                                                                                                                                                                                                                                                   |
|                                                                                                                                               | Output of heat source is unable to meet demand of heating system.                                                                                                                                                                                                                                   | Compare output of heat source to the requirements of the heating system.                                                                                                                                                                                                                                                                                                                                                                                             |
|                                                                                                                                               | The red and green LED's on the power module do not light up during a call for heat.                                                                                                                                                                                                                 | The zone valve controller may be defective or there is no power being supplied to the panel or the power module is not on. If this is so, switch the power module to by-pass mode. When the Bypass switch is placed in the BY-PASS (ON) position, the green LED will be lit, indicating that the panel is powered with 110V, and the Primary and Secondary pumps will run. This will provide constant circulation so long as there is still 110V power to the panel. |
|                                                                                                                                               | Circulator is not on during a call for heat. (Use a stethoscope or similar device to verify)                                                                                                                                                                                                        | The power box or circulator may be defective.                                                                                                                                                                                                                                                                                                                                                                                                                        |
| When zone valves are installed outside the panel a qualified electrician should verify 24V power is supplied to the thermostats and actuator. | The 24V transformer may have failed. If this so, switch the power module to Bypass mode. This will provide constant circulation so long as there is still 110V power to the panel. Prior to Bypass mode selection, any zone valves must be opened manually to avoid dead-heading of the circulator. |                                                                                                                                                                                                                                                                                                                                                                                                                                                                      |
| <b>High Temperature Within Room</b>                                                                                                           | Check current setting of the thermostat.                                                                                                                                                                                                                                                            | Adjust the temperature setting on thermostat to a lower setting.                                                                                                                                                                                                                                                                                                                                                                                                     |
|                                                                                                                                               | High supply mixed fluid temperature.                                                                                                                                                                                                                                                                | Adjust the Thermostatic Mixing Valve to the appropriate settings.                                                                                                                                                                                                                                                                                                                                                                                                    |
|                                                                                                                                               | Installed electronic actuators remain open after the thermostat is satisfied.                                                                                                                                                                                                                       | An obstruction inside the zone valve is not allowing the actuator to fully close or the thermostat is still calling for heat.                                                                                                                                                                                                                                                                                                                                        |
|                                                                                                                                               | Bypass switch(es) may be on.                                                                                                                                                                                                                                                                        | Check that the Bypass switches on the power box are in the BY-PASS (OFF) position.                                                                                                                                                                                                                                                                                                                                                                                   |



**TWH 70 MBH Tankless Water Heater Mixing Panel with Zoning**

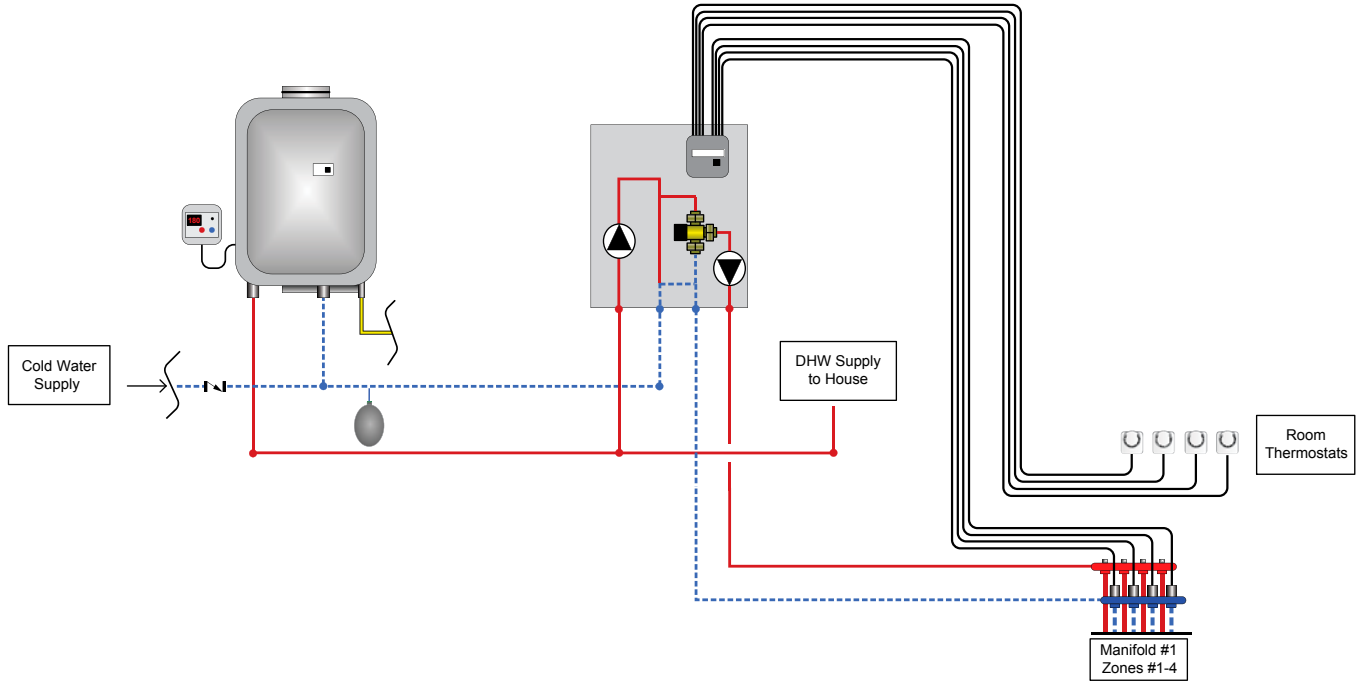

**Notes:**

- A) Check local codes for permissible heat source. Heat sources rated as DHW cannot be used for heating only.
- B) Secondary zoning with a DHW heat source is possible. Check local codes for permissible zoning.
- C) This drawing is for illustrative purposes only. It is not intended to be used as a wiring or piping diagram.

**Not all required components are shown. Local codes, regulations, and authorities have final jurisdiction.**









### **Heat Link**<sup>®</sup> Canada

Manufactured & distributed by HeatLink Group Inc.

**Head Office:**

4603E - 13<sup>th</sup> Street N.E.  
Calgary, Alberta, T2E 6M3

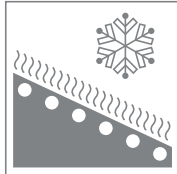

### **Eastern Canada Distribution Center:**

2810 Argenta Road, Units 5-7  
Mississauga, Ontario, L5N 8L2

Toll Free: 1-800-661-5332

Fax: 1-866-450-1155

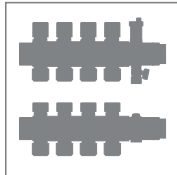

### **Heat Link**<sup>®</sup> China

Distributed by Cathay-Links International

Phone: 852-25693213

Fax: 852-25359271

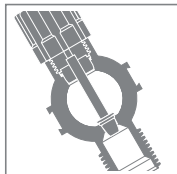

### **Heat Link**<sup>®</sup> Ireland

Distributed by Jamoni Ltd.

Phone: 057 - 932 4062

Fax: 057 - 932 4063

Freephone: 1800-311338

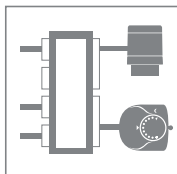

### **Heat Link**<sup>®</sup> México

Distributed by Distribuidora Caisa S.A. de C.V.

Phone: (52-55) 3300-4400

Fax: (52-55) 3300-4406



### **Heat Link**<sup>®</sup> United States

Distributed by HeatLink Group Inc.

**USA Distribution Center:**

1000 - 100<sup>th</sup> Street SW, Suite B

Byron Center, MI, 49315

Toll Free: 1-800-661-5332

Fax: 1-800-869-6098

[www.heatlinkgroup.com](http://www.heatlinkgroup.com)

*HeatLink, the HeatLink logo, and "Mechanical Room in a Box" logo are either registered trademarks or trademarks of HeatLink Group Inc.*